



DSEControl



DEEP SEA ELECTRONICS

DSEE050 Operator Manual

Document Number: 057-300

Author: Anthony Manton



Deep Sea Electronics Ltd
Highfield House
Hunmanby
North Yorkshire
YO14 0PH
ENGLAND

Sales Tel: +44 (0) 1723 890099

E-mail: sales@deepseaelectronics.com
Website: www.deepseaelectronics.com

DSEE050 Operator Manual

© Deep Sea Electronics Ltd.

All rights reserved. No part of this publication may be reproduced in any material form (including photocopying or storing in any medium by electronic means or other) without the written permission of the copyright holder except in accordance with the provisions of the Copyright, Designs and Patents Act 1988.

Applications for the copyright holder's written permission to reproduce any part of this publication must be addressed to Deep Sea Electronics Ltd at the address above.

The DSE logo and the names DSEGenset®, DSEAts®, DSEControl® and DSEPower® are UK registered trademarks of Deep Sea Electronics Ltd.

Any reference to trademarked product names used within this publication is owned by their respective companies.

Deep Sea Electronics Ltd reserves the right to change the contents of this document without prior notice.

Amendments Since Last Publication

Amd. No.	Comments
1	Initial Release
1.1	Added DSE part number of PCAN-USB interface (016-179)
2	Added unit conversion menu
3	Amendment made to supply voltage

TABLE OF CONTENTS

Section	Page
1 INTRODUCTION.....	5
1.1 CLARIFICATION OF NOTATION.....	6
1.2 GLOSSARY OF TERMS.....	6
1.3 BIBLIOGRAPHY	7
1.3.1 INSTALLATION INSTRUCTIONS.....	7
1.3.2 MANUALS	7
1.3.3 TRAINING GUIDES	7
2 SPECIFICATION.....	8
2.1 OPERATING TEMPERATURE.....	8
2.2 TERMINAL SPECIFICATION	8
2.3 POWER SUPPLY.....	8
2.3.1 MODULE SUPPLY INSTRUMENTATION DISPLAY.....	8
2.4 VREF OUTPUT	9
2.5 INPUTS.....	9
2.5.1 DIGITAL INPUTS	9
2.5.2 ANALOGUE VOLTAGE	9
2.5.3 ANALOGUE CURRENT.....	10
2.5.4 ANALOGUE RESISTIVE.....	10
2.5.4.1 DISPLAY BACKLIGHT.....	11
2.8 CAN.....	12
2.9 DIMENSIONS AND MOUNTING	13
2.9.1 DIMENSIONS.....	13
2.9.2 PANEL CUTOUT.....	14
2.9.3 WEIGHT	15
2.9.4 FIXING.....	15
2.9.4.1 TORQUE SETTING OF FIXING NUT.....	15
2.10 APPLICABLE STANDARDS	15
2.10.1 ENCLOSURE CLASSIFICATIONS.....	16
2.10.1.1 IP CLASSIFICATIONS.....	16
3 INSTALLATION.....	17
3.1 CONNECTION DESCRIPTIONS	17
3.2 TYPICAL WIRING DIAGRAM.....	18
3.2.1 EARTH SYSTEMS.....	19
3.2.1.1 NEGATIVE EARTH.....	19
3.2.1.2 POSITIVE EARTH	19
3.2.1.3 FLOATING EARTH.....	19
3.2.2 TYPICAL ARRANGEMENT OF CAN LINK.....	20
4 OPERATION.....	21
4.1 FASCIA	21
4.1.1 BUTTONS	21
4.1.2 INSTRUMENTATION.....	22
4.1.2.1 ENGINE AND ANALOGUE INPUT INSTRUMENTATION	22
4.1.2.2 DIAGNOSTIC TROUBLE CODES (DTCS).....	24
4.1.2.3 DISPLAY BRIGHTNESS.....	26
4.1.2.4 DEVICE INFORMATION.....	27
4.1.2.5 UNIT CONVERSION.....	27
4.1.3 ICONS	29
4.1.3.1 LAMPS	29
4.1.3.2 ICONS.....	30
5 FAULT FINDING.....	32
6 MAINTENANCE, SPARES, REPAIR AND SERVICING	34
6.1 DSEE050 CONNECTOR HARNESS (016-176).....	34

6.2	DSEE050 CONFIGURATION HARNESS (016-177)	35
6.3	PCAN-USB CONNECTION DETAILS	35
7	WARRANTY	36
8	DISPOSAL	36
8.1	WEEE (WASTE ELECTRICAL AND ELECTRONIC EQUIPMENT)	36

1 INTRODUCTION

This document details the installation and operation requirements of the DSEE050 module and is part of the DSEControl® range of products.

The manual forms part of the product and should be kept for the entire life of the product. If the product is passed or supplied to another party, ensure that this document is passed to them for reference purposes.

This is not a *controlled document*. DSE do not automatically inform on updates. Any future updates of this document are included on the DSE website at [www. deepseaelectronics.com](http://www.deepseaelectronics.com)

DSE Configuration Suite PC Software allows alteration of selected operational sequences, timers, alarms and operational sequences.

The module is housed in a robust plastic case suitable for panel mounting. Connections to the module are via locking plug and sockets.



DSEE050 connects to J1939 enabled ECUs to display instrumentation from the engine, status information and optionally send speed control instructions using the J1939 TSC1 (Torque and Speed Control) message.

While DSEE050 provides no internal protections for the engine, it serves as a display for the engine ECU DM1 (Diagnostic Message 1).



1.1 CLARIFICATION OF NOTATION

Clarification of notation used within this publication.

 NOTE:	Highlights an essential element of a procedure to ensure correctness.
 CAUTION!	Indicates a procedure or practice, which, if not strictly observed, could result in damage or destruction of equipment.
 WARNING!	Indicates a procedure or practice, which could result in injury to personnel or loss of life if not followed correctly.

1.2 GLOSSARY OF TERMS

Term	Description
DSEExxx	All modules in the DSEExxx range of <i>Engine Only</i> controllers.
CAN	Controller Area Network Vehicle standard to allow digital devices to communicate to one another.
DEF	Diesel Exhaust Fluid (AdBlue) A liquid used as a consumable in the SCR process to lower nitric oxide and nitrogen dioxide concentration in engine exhaust emissions.
DM1	Diagnostic Message 1 A DTC that is currently active on the engine ECU. If the ECU powers down after a fault shutdown, DM1s are moved to the DM2 list and cleared from the DM1 list.
DM2	Diagnostic Message 2 A DTC that was previously active on the engine ECU and has been stored in the ECU's internal memory. This includes any faults that may have occurred during the last run. Therefore DM2s are important to know the reason of the last shutdown in situations where the ECU powers down when the engine is stopped.
DM3	Diagnostic Message 3 A message sent to the engine ECU to instruct it to clear/reset the list of previously active DTCs (DM2s).
DPF	Diesel Particulate Filter A filter fitted to the exhaust of an engine to remove diesel particulate matter or soot from the exhaust gas.
DPTC	Diesel Particulate Temperature Controlled Filter A filter fitted to the exhaust of an engine to remove diesel particulate matter or soot from the exhaust gas which is temperature controlled.
DTC	Diagnostic Trouble Code The name for the fault code sent by an engine ECU consisting of a Suspect Parameter Number (SPN), Failure Mode Identifier (FMI) and an Occurrence Count (OC).
ECU/ECM	Engine Control Unit/Management An electronic device that monitors engine parameters and regulates the fuelling.
FMI	Failure Mode Indicator A part of DTC that indicates the type of failure, e.g. high, low, open circuit etc.
HEST	High Exhaust System Temperature Initiates when DPF filter is full in conjunction with an extra fuel injector in the exhaust system to burn off accumulated diesel particulate matter or soot.
OC	Occurrence Count A part of DTC that indicates the number of times that failure has occurred.

Continued Overleaf.

Term	Description
PCAN-USB	USB to CAN converter interface for Windows™ PCs. See section entitled <i>Maintenance, Spares, Repair and Servicing</i> elsewhere in this document for part number details.
PGN	Parameter Group Number A CAN address for a set of parameters that relate to the same topic and share the same transmission rate.
PLC	Programmable Logic Controller A programmable digital device used to create logic for a specific purpose.
SCR	Selective Catalytic Reduction A process that uses DEF with the aid of a catalyst to convert nitric oxide and nitrogen dioxide into nitrogen and water to reduce engine exhaust emission.
SPN	Suspect Parameter Number A part of DTC that indicates what the failure is, e.g. oil pressure, coolant temperature, turbo pressure etc.
TSC1	Torque/Speed Control 1 A method of speed control of electronic engines. This is the speed control method supported by the DSEE050 device.

1.3 BIBLIOGRAPHY

This document refers to and is referred by the following DSE publications which are obtained from the DSE website: www.deepseaelectronics.com or by contacting DSE technical support: support@deepseaelectronics.com.

1.3.1 INSTALLATION INSTRUCTIONS

Installation instructions are supplied with the product in the box and are intended as a 'quick start' guide only.

DSE Part	Description
053-242	DSEE050 Installation Instructions

1.3.2 MANUALS

Product manuals are obtained from the DSE website: www.deepseaelectronics.com or by contacting DSE technical support: support@deepseaelectronics.com.

DSE Part	Description
057-299	DSEE050 Configuration Suite PC Software Manual

1.3.3 TRAINING GUIDES

Training guides are provided as 'hand-out' sheets on specific subjects during training sessions and contain specific information regarding to that subject.

DSE Part	Description
056-117	J1939 29-bit Identifier

2 SPECIFICATION

2.1 OPERATING TEMPERATURE

Module	Specification
DSEE050	-40 °C +85 °C (-40 °F +185 °F)

2.2 TERMINAL SPECIFICATION

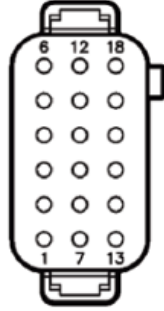
Description	Specification	
Connection Type	Two-part connector. Male part fitted to module Female part supplied in module packing case.	
Minimum Cable Size	0.5 mm ² (AWG 20)	
Maximum Cable Size	2.0 mm ² (AWG 13) providing suitable connector pins are used.	

2.3 POWER SUPPLY

Description	Specification
Applicable Pins	A1, A7
Minimum Supply Voltage	8 V continuous.
Cranking Dropouts	Able to survive 0 V for 100 ms providing the supply was at least 10 V before the dropout and recovers to 5 V afterwards.
Maximum Supply Voltage	32 V continuous (60 V protection for one minute)
Reverse Polarity Protection	-32 V continuous
Maximum Operating Current	300 mA at 12 V 150 mA at 24 V
Maximum Operating Current with Display Heater Active	640 mA at 12 V 310 mA at 24 V
Maximum Standby Current	115 mA at 12 V 65 mA at 24 V

2.3.1 MODULE SUPPLY INSTRUMENTATION DISPLAY

Description	Specification
Range	0 V to 70 V DC (Maximum continuous operating voltage of 32 V DC)
Resolution	0.1 V
Accuracy	1 % full scale (± 0.35 V)

2.4 VREF OUTPUT

Provides a supply output for use with external sensors.

Description	Specification
Applicable Pins	A13, A17
Voltage Output	5 V / 10 V configurable by DSE Configuration Suite PC Software.
Accuracy	$\pm 5\%$
Maximum Source current	100 mA
Voltage Feedback	0 V to 10.8 V
Resolution	12-bits
Accuracy	$\pm 1\%$ FSD
Protection	Short to ground only

2.5 INPUTS

2.5.1 DIGITAL INPUTS

Description	Specification
Applicable Pins	A5, A6, A12, A18
Number	4 configurable analogue inputs, able to be configured to operate as digital inputs.
Impedance	$> 3\text{ k}\Omega$
Pull-up resistance	Not Applicable. 3 mA current source from resistive sender circuit.
Pull-down resistance	4.3 k Ω
High level voltage threshold	6 V
Low level voltage threshold	2 V
Active Mode	Configurable by DSE Configuration Suite PC Software (Active High, Active Low)
Wetting Current Active Low	3 mA $\pm 10\%$
Wetting Current Active High	2.8 mA $\pm 2\%$ at 12 V 5.6 mA $\pm 2\%$ at 24 V
Debounce	100 ms
Transient Over/undervoltage	$\pm 36\text{ V}$

2.5.2 ANALOGUE VOLTAGE

Description	Specification
Applicable Pins	A5, A6, A12, A18
Input range	0 V to 10 V nominal (12.1 V max)
Resolution	12 bits
Accuracy	$\pm 1\%$ FSD
Precision	0.2 % FSD
Input Resistance	$>10\text{ k}\Omega$
Common Mode Range	0 V
Sampling Rate	5 ms
Transient Over/Undervoltage Protection	$\pm 36\text{ V}$

2.5.3 ANALOGUE CURRENT

Description	Specification
Applicable Pins	A5, A6, A12, A18
Input range	0 mA to 20 mA nominal (22 mA max)
Resolution	12 bits
Accuracy	± 1 % FSD
Precision	0.2 % FSD
Input Resistance Max	150 Ω ± 1 %
Common Mode Range	0 V
Transient Over/Undervoltage Protection	± 36 V

2.5.4 ANALOGUE RESISTIVE

Description	Specification
Applicable Pins	A5, A6, A12, A18
Input range	0 Ω to 3 k Ω nominal (3200 Ω max)
Resolution	12 bits
Accuracy	± 1 % FSD
Precision	0.2 % FSD
Input Resistance	Not Applicable as it's a constant current source
Wetting Current	3 mA ± 10 %
Common Mode Range	0 V
Sampling Rate	5 ms
Transient Over/Undervoltage Protection	± 36 V

2.6 OUTPUTS

 **NOTE:** For further details of module configuration, refer to DSE Publication: 057-299 *DSEE050 Configuration Suite PC Software Manual*. Contact supplier or consult the device configuration source for full details of the configured outputs.

Description	Specification
Applicable Pins	A14, A15, A16
Number	3
Arrangement	High Side supplied from Plant Volts +ve.
Current	1 A at 85 °C (1 A at 185 °F)

2.7 FASCIA

2.7.1 DISPLAY

Description	Specification
Type	Optically Bonded T.F.T with A.R. Coating.
Size	3.5 "
Resolution	320 pixels X 240 pixels
Colour Depth	16-bit colour, RGB interface

2.7.1.1 DISPLAY BACKLIGHT

Device State	Display Backlight State
Off	Off
On, Normal Operating Conditions	As configured (Factory Setting 80 %)
Low Power/Sleep Mode	Off
Low DC Voltage (eg During Engine Cranking)	Off

2.7.2 KEYBOARD BACKLIGHT

Device State	Keyboard Backlight State
Off	Off
On, Normal Operating Conditions	All keys illuminated
Low Power/Sleep Mode	Off
High Ambient Temperature	On

2.8 CAN

NOTE: For further details of module configuration, refer to DSE Publication: 057-299 *DSEE050 Configuration Suite PC Software Manual*.

NOTE: DSE Stock and supply PCAN-USB IPEH-002021. DSE Part number 016-179. Contact sales@deepseaelectronics.com.

The CAN port is used for two functions:

1. To communicate with the engine ECU to read information and optionally control engine speed.
2. To connect the device to a PC for configuration by DSE Configuration Suite PC Software. In conjunction with PCAN-USB (IPEH-002021 or IPEH-002022) from Peak Systems (<https://www.peak-system.com>) or from sales@deepseaelectronics.com, DSE part number 016-179.

Description	Specification
Applicable Pins	A2, A3, A4, A8, A9, A10
Protocol	CAN 2.0 B J1939
Termination Resistor	120 Ω internal resistor, configurable by DSE Configuration Suite PC Software
Supported Rates	125 kbit/s 250 kbit/s 500 kbit/s
Additional Features	In/out pass-through connection Auto recovery from bus-off conditions Separate pins provided for CAN in / out

2.9 DIMENSIONS AND MOUNTING

2.9.1 DIMENSIONS

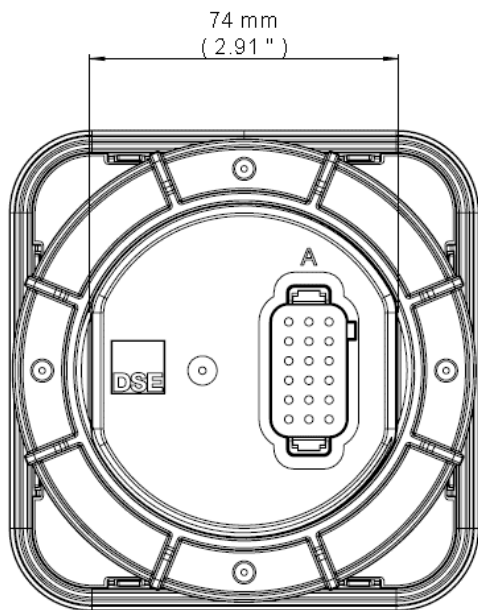
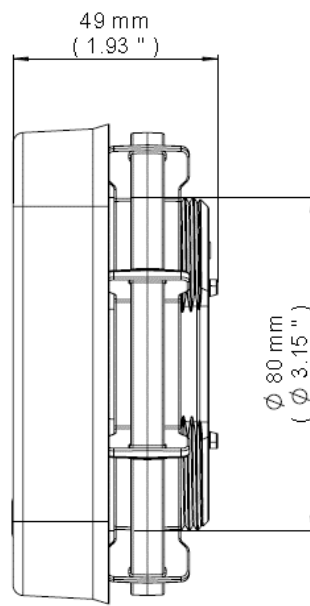
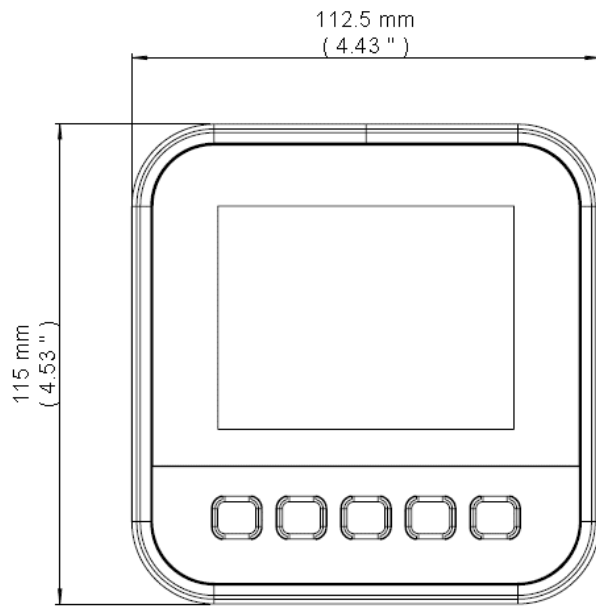

2.9.2 PANEL CUTOUT

82 mm (3.23 ") hole is suitable. Maximum Panel Thickness: 6 mm (0.24 ")

If a punch or milling machine is available, adding 'flats' at 74 mm (2.91 ") spacing serves to prevent rotation of the device in the panel cut-out.

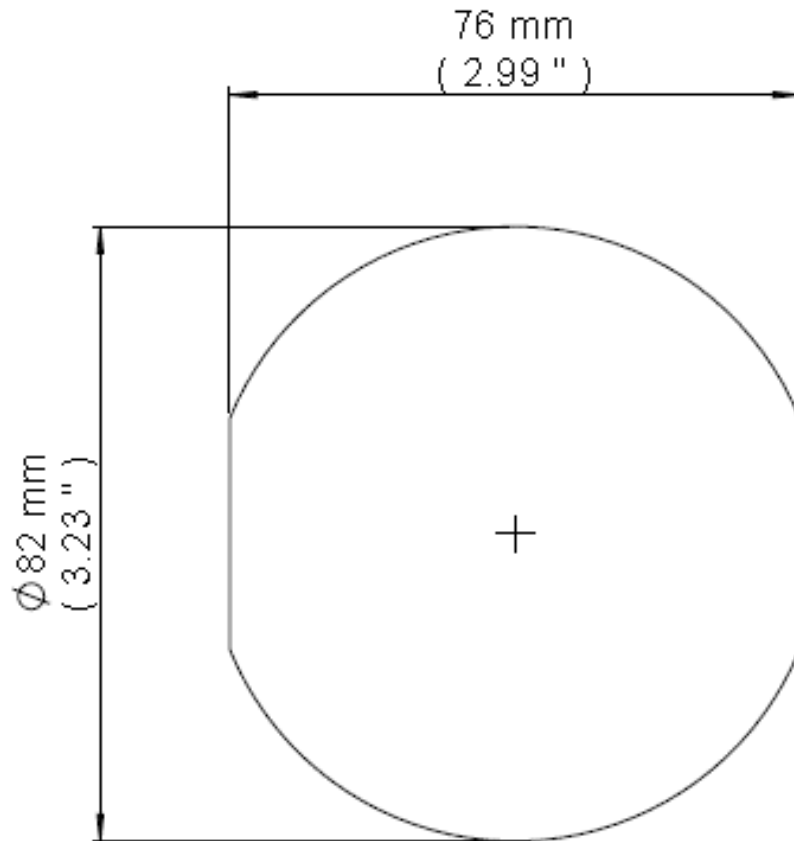

2.9.3 WEIGHT

<1 kg
(<35.3 oz)

2.9.4 FIXING

 **NOTE: In conditions of excessive vibration, mount the housing on suitable anti-vibration mountings.**

The device is held into the panel fascia using the large nut provided.

- Place the controller into the panel aperture.
- Attached the supplied fixing nut and hand tighten to provide adequate fixing (see below).
- Attach the connector plug (Plug A) and push home to click into place.

2.9.4.1 TORQUE SETTING OF FIXING NUT

8 Nm
5.9 ft-lb

2.10 APPLICABLE STANDARDS

Standard	Description
BS 4884-1	This document conforms to BS4884-1 1992 Specification for presentation of essential information.
BS 4884-2	This document conforms to BS4884-2 1993 Guide to content
BS 4884-3	This document conforms to BS4884-3 1993 Guide to presentation
BS EN 60068-2-1 (Minimum temperature)	-40 °C (-40 °F)
BS EN 60068-2-2 (Maximum temperature)	+85 °C (185 °F)
BS EN 61010	Safety requirements for electrical equipment for measurement, control, and laboratory use
BS EN 61000-6-2	EMC Generic Immunity Standard (Industrial)
BS EN 61000-6-4	EMC Generic Emission Standard (Industrial)
BS EN 60529 (Degrees of protection provided by enclosures)	IP67 front and rear

In line with our policy of continual development, Deep Sea Electronics, reserve the right to change specification without notice.

2.10.1 ENCLOSURE CLASSIFICATIONS

2.10.1.1 IP CLASSIFICATIONS

The modules specification under BS EN 60529 Degrees of protection provided by enclosures

IP67 (Front of module when module is installed into the control panel with the optional sealing gasket).

IP67 (front of module when module is installed into the control panel WITHOUT being sealed to the panel)

First Digit		Second Digit	
Protection against contact and ingress of solid objects		Protection against ingress of water	
0	No protection	0	No protection
1	Protected against ingress solid objects with a diameter of more than 50 mm. No protection against deliberate access, e.g. with a hand, but large surfaces of the body are prevented from approach.	1	Protection against dripping water falling vertically. No harmful effect must be produced (vertically falling drops).
2	Protected against penetration by solid objects with a diameter of more than 12 mm. Fingers or similar objects prevented from approach.	2	Protection against dripping water falling vertically. There must be no harmful effect when the equipment (enclosure) is tilted at an angle up to 15° from its normal position (drops falling at an angle).
3	Protected against ingress of solid objects with a diameter of more than 2.5 mm. Tools, wires etc. with a thickness of more than 2.5 mm are prevented from approach.	3	Protection against water falling at any angle up to 60° from the vertical. There must be no harmful effect (spray water).
4	Protected against ingress of solid objects with a diameter of more than 1 mm. Tools, wires etc. with a thickness of more than 1 mm are prevented from approach.	4	Protection against water splashed against the equipment (enclosure) from any direction. There must be no harmful effect (splashing water).
5	Protected against harmful dust deposits. Ingress of dust is not totally prevented but the dust must not enter in sufficient quantity to interface with satisfactory operation of the equipment. Complete protection against contact.	5	Protection against water projected from a nozzle against the equipment (enclosure) from any direction. There must be no harmful effect (water jet).
6	Protection against ingress of dust (dust tight). Complete protection against contact.	6	Protection against heavy seas or powerful water jets. Water must not enter the equipment (enclosure) in harmful quantities (splashing over).
		7	No ingress of water in harmful quantity when the enclosure is immersed in water under defined conditions of pressure and time (up to 1 m of submersion)

3 INSTALLATION

The module is designed to be mounted on the panel fascia. For dimension and mounting details, see the section entitled *Dimension and Mounting* elsewhere in this document.

3.1 CONNECTION DESCRIPTIONS

NOTE: Screened 120 Ω impedance cable specified for use with CAN must be used for the CAN links.
 DSE stock and supply Belden cable 9841 which is a high quality 120 Ω impedance cable suitable for CAN use (DSE part number 016-030).

NOTE: Terminals A11, and A13 are internally connected to A1.

NOTE: For further details of module configuration, refer to DSE Publication: 057-299 *DSEE050 Configuration Suite PC Software Manual*.

	Pin	Description	Notes
	A1	DC Plant Supply Input (Negative)	Battery negative supply for the device.
	A2	CAN SCR	Connect to Engine ECU CAN SCR
	A3	CAN L (in)	Connect to Engine ECU CAN L
	A4	CAN H (in)	Connect to Engine ECU CAN L
	A5	Input D	Analogue / Digital input D
	A6	Input A	Analogue / Digital input A
	A7	DC Plant Supply input (Positive)	Battery positive supply for the device.
	A8	CAN SCR	Optional to connect to additional CAN devices. Internally connected to A2
	A9	CAN L (out)	Optional to connect to additional CAN devices. Internally connected to A3
	A10	CAN H (out)	Optional to connect to additional CAN devices. Internally connected to A4
	A11	Input Common GND	Provides ground reference to all inputs (A5, A6, A12, A18)
	A12	Input B	Analogue / Digital input B
	A13	VREF Negative	Negative connection for the VREF Output voltage.
	A14	Output A	Max 1 A at the voltage applied to A1
	A15	Output B	Max 1 A at the voltage applied to A1
	A16	Output C	Max 1 A at the voltage applied to A1
	A17	VREF Positive OUT	Positive connection for the VREF Output voltage.
	A18	Input C	Analogue / Digital input C

3.2 TYPICAL WIRING DIAGRAM

NOTE: As systems have differing requirements, these diagrams show only a typical system and do not intend to show a complete system.

NOTE: This diagram shows connection to a Negative Earth system. For Positive Earth and Floating Earth systems, see section entitled *Earth Systems* elsewhere in this document.

NOTE: Screened 120 Ω impedance cable specified for use with CAN must be used for the CAN links.
 DSE stock and supply Belden cable 9841 which is a high quality 120 Ω impedance cable suitable for CAN use (DSE part number 016-030).

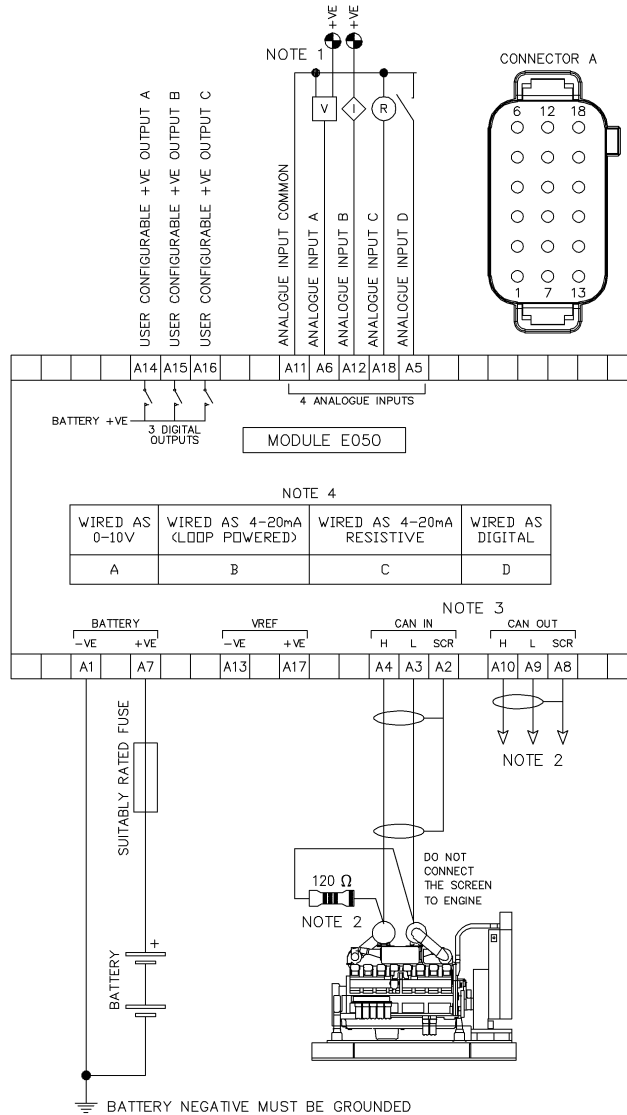

NOTE 1. ANALOGUE INPUT COMMON MUST NOT BE GROUNDED AS IT IS LINKED INTERNALLY TO TERMINAL A1.

NOTE 2. 120 Ω TERMINATING RESISTOR MAY BE REQUIRED EXTERNALLY, SEE EXTERNAL EQUIPMENT MANUFACTURERS LITERATURE.

NOTE 3. CAN IN AND CAN OUT ARE LINKED INTERNALLY.

NOTE 4. ANALOGUE INPUTS CAN BE CONFIGURED AS EITHER A DIGITAL INPUT, RESISTIVE INPUT, 0-10V INPUT, 4-20mA INPUT, OR ANY COMBINATION OF THE ABOVE.

3.2.1 EARTH SYSTEMS

3.2.1.1 NEGATIVE EARTH

The typical wiring diagrams located within this document show connections for a negative earth system (the battery negative connects to Earth).

3.2.1.2 POSITIVE EARTH

When using a DSE module with a Positive Earth System (the battery positive connects to Earth), the following points must be followed:

Follow the typical wiring diagram as normal for all sections **except** the earth points. All points shown as Earth on the typical wiring diagram should connect to **battery negative** (not earth).

3.2.1.3 FLOATING EARTH

Where neither the battery positive or battery negative terminals are connected to earth the following points must to be followed:

Follow the typical wiring diagram as normal for all sections **except** the earth points. All points shown as Earth on the typical wiring diagram should connect to **battery negative** (not earth).

3.2.2 TYPICAL ARRANGEMENT OF CAN LINK

NOTE: For further details of module configuration, refer to DSE Publication: 057-299 *DSEE050 Configuration Suite PC Software Manual*.

NOTE: Screened 120 Ω impedance cable specified for use with CAN must be used for the CAN connection.

DSE stock and supply Belden cable 9841 which is a high quality 120 Ω impedance cable suitable for CAN use (DSE part number 016-030)

NOTE: A termination resistor **MUST** be fitted to the first and last unit on the CAN link. An internal 120 Ω termination resistor is fitted. This is configurable by DSE Configuration Suite PC Software.

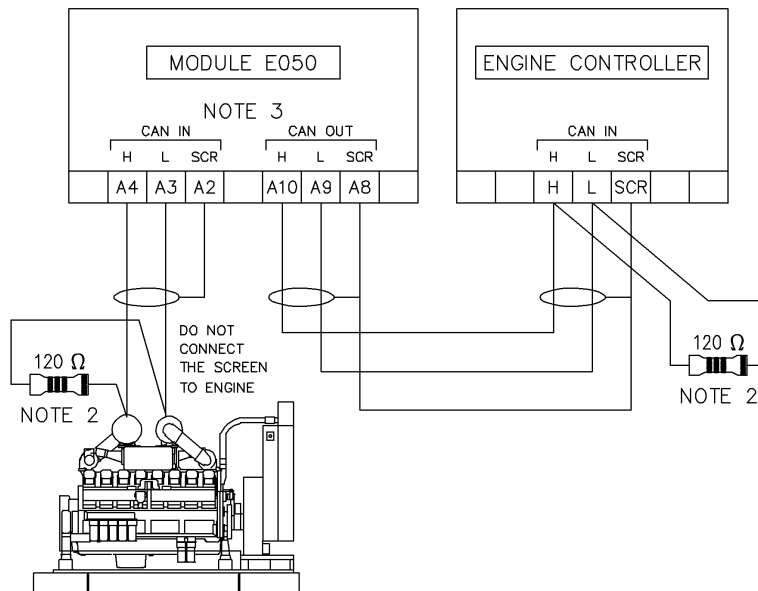

NOTE 2. 120 Ω TERMINATING RESISTOR MAY BE REQUIRED EXTERNALLY, SEE EXTERNAL EQUIPMENT MANUFACTURERS LITERATURE.

NOTE 3. CAN IN AND CAN OUT ARE LINKED INTERNALLY.

NOTE 4. ANALOGUE INPUTS CAN BE CONFIGURED AS EITHER A DIGITAL INPUT, RESISTIVE INPUT, 0–10V INPUT, 4–20mA INPUT, OR ANY COMBINATION OF THE ABOVE.

4 OPERATION

4.1 FASCIA



4.1.1 BUTTONS

NOTE: This section documents the Factory (Default) settings of the DSEE050. Due to the configurable nature of the device this is subject to change as required by the supplier. Contact supplier or consult the device configuration source for full details of the configured instrumentation.

NOTE: Where TSC1 (speed control) is enabled in the configuration (Factory Setting is OFF), manually changed engine speed is not maintained through a power cycle. After application of DC power to the device, engine speed returns to the configured *Default Engine Speed* (Factory Setting 1500 RPM).

Icon	Description
	Reduce engine speed providing the device is configured to send TSC1 speed control messages, the ECU is suitably configured to receive them, and the engine speed is above the configured <i>Crank Disconnect</i> speed.
	View engine Diagnostic Trouble Codes.
	View next Instrumentation Screen
	View previous Instrumentation Screen
	Increase engine speed providing the device is configured to send TSC1 speed control messages, the ECU is suitably configured to receive them, and the engine speed is above the configured <i>Crank Disconnect</i> speed.

4.1.2 INSTRUMENTATION

NOTE: This section documents the Factory (Default) settings of the DSEE050. Due to the configurable nature of the device this is subject to change as required by the supplier. Contact supplier or consult the device configuration source for full details of the configured instrumentation.

Instrumentation falls into three categories as detailed below. Press  to cycle the display between them.

- Engine and analogue input instrumentation.
- Diagnostic Trouble Codes (DTCs).
- Display brightness setting.
- Device information.

4.1.2.1 ENGINE AND ANALOGUE INPUT INSTRUMENTATION

NOTE: This section documents the Factory (Default) settings of the DSEE050. Due to the configurable nature of the device this is subject to change as required by the supplier. Contact supplier or consult the device configuration source for full details of the configured instrumentation.

Sentinel Values





Out of Range instruments or instruments in an *Error* condition display the following:

Display	Description
- - - -	Under Range. The value is under the minimum value allowed for the instrument.
+ + + +	Over Range. The value is over the maximum value allowed for the instrument.
XXXXXX	Unimplemented. No data is available for this instrument. This occurs if the instrument is not transmitted by the CAN ECU or the input assigned to the instrument is not configured.
# # # #	Bad Data or CAN connection is not available. This occurs upon no data being received from the CAN ECU in situations such as <i>Engine not Running</i> or an error with the CAN connection.



Page 1 - Summary

Page Display	Description
	Engine Speed Engine Oil Pressure Engine Coolant Temperature Battery Voltage of the ECU Engine Total Running Hours



Page 2 - Engine

Page Display			Description
 390 kPa	390	kPa	Engine Coolant Pressure
 224 kPa	224	kPa	Engine Intake Manifold Pressure
 28 °C	28	°C	Engine Intake Manifold Temperature
 600 °C	600	°C	Engine Exhaust Temperature
 498 °C	498	°C	Engine Oil Temperature

Page 3 - Fuel



Page Display			Description
 224 °C	224	°C	Fuel Temperature
 28 l/h	28	l/h	Fuel Rate
 600 kPa	600	kPa	Fuel Pressure

Page 4 – DPF and Aftertreatment

Page Display			Description
 90 %	90	%	DPF1 (Diesel Particulate Filter) Soot Percentage
 224 %	224	%	DPF1 (Diesel Particulate Filter) Ash Percentage
 28 mm	28	mm	After Treatment 1 DEF (Diesel Exhaust Fluid) Level

4.1.2.2 DIAGNOSTIC TROUBLE CODES (DTCs)

 **NOTE:** For a full list of all SPN/FMI and their detailed descriptions, consult SAE J1939 specification or consult the manufacturer/supplier of the ECU connected.

When available Diagnostic Trouble Codes (DTCs) are displayed. Press  and  to cycle through the available DTCs.

DM1 – Currently Active DTCs

DM1s are displayed in White numerals (in the Dark Theme) or Black numerals (in the Light Theme).

DTC Display	Description
SPN 190	SPN: Suspect Parameter Number. This refers to the SAE J1939 database of SPNs and indicates the parameter that is in the fault condition.
FMI 0	FMI: Failure Mode Identification. This refers to the SAE J1939 database of FMIs and indicates the type of failure indicated by the ECU.
OC 1	OC: Occurrence Count. This is a count of how many times this particular SPN/FMI combination has occurred.

DM2 – Previously Active DTCs

DM2s are displayed in Grey numerals.

 **NOTE:** When clearing the DM2 DTCs a message is sent from the DSEE050 (DM3). This message is sent from the preconfigured source address of the DSEE050. This is the same source address used for TSC1 Messages (Factory Default 0xEA (234)).

When available, press  to clear the currently viewed DM2 from the ECU DM2 list. If this function is not supported by the ECU, the DTC reappears the next time the DM2s are transmitted by the ECU.

DTC Display	Description
SPN 175	SPN: Suspect Parameter Number. This refers to the SAE J1939 database of SPNs and indicates the parameter that is in the fault condition.
FMI 3	FMI: Failure Mode Identification. This refers to the SAE J1939 database of FMIs and indicates the type of failure indicated by the ECU.
OC 3	OC: Occurrence Count. This is a count of how many times this particular SPN/FMI combination has occurred.

Common SPNs

 **NOTE: For a full list of all SPN/FMI and their detailed descriptions, consult SAE J1939 specification or consult the manufacturer/supplier of the ECU connected.**

SPN	Description
100	Engine Oil Pressure
102	Engine Intake Manifold 1 Pressure
105	Engine Intake Manifold 1 Temperature
110	Engine Coolant Temperature
173	Engine Exhaust Temperature
175	Engine Oil Temperature
190	Engine Speed
3517	After Treatment 1 DEF (Diesel Exhaust Fluid) Level

FMI

 **NOTE: For a full list of all SPN/FMI and their detailed descriptions, consult SAE J1939 specification or consult the manufacturer/supplier of the ECU connected.**

FMI	Description
0	High – most severe (3)
1	Low – most severe (3)
2	Erratic, Intermittent or Incorrect
3	Voltage Above Normal
4	Voltage Below Normal
5	Current Below Normal
6	Current Above Normal
7	Not Responding Properly
8	Abnormal Frequency, Pulse Width or Period
9	Abnormal Update Rate
10	Abnormal Rate of Change
11	Other Failure Mode
12	Failure
13	Out of Calibration
14	Special Instruction
15	High – least severe (1)
16	High – moderate severity (2)
17	Low – least severe (1)
18	Low – moderate severity (2)
19	Data Error
20	Data Drifted High
21	Data Drifted Low

4.1.2.3 DISPLAY BRIGHTNESS

NOTE: For further details of module configuration, refer to DSE Publication: *057-299 DSEE050 Configuration Suite PC Software Manual*.



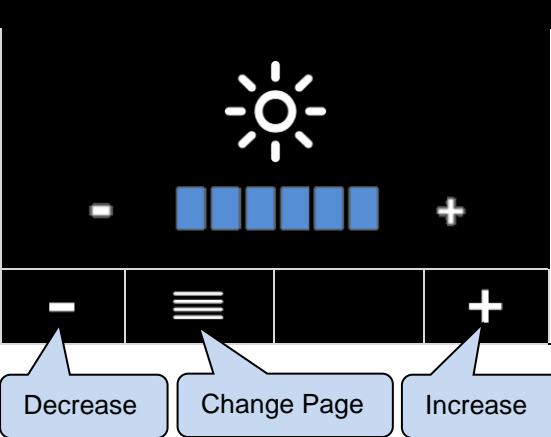

Allows further adjustment of the display brightness away from the value configured using DSE Configuration Suite PC Software. The chosen brightness is maintained over a power cycle of the device.

Description	
	Shows the position of the brightness setting relative to the minimum possible and maximum possible settings.

4.1.2.4 DEVICE INFORMATION

NOTE: For further details of module configuration, refer to DSE Publication: *057-299 DSEE050 Configuration Suite PC Software Manual.*

Displays information about the device.



		Description
	EO50 eView	
	V1.13	Shows the device firmware version
	250 kbit/s	Shows the baud rate setting for the device CAN interface.
	24.0 V	Shows the measured battery voltage of the device.

4.1.2.5 UNIT CONVERSION

NOTE: For further details of module configuration, refer to DSE Publication: *057-299 DSEE050 Configuration Suite PC Software Manual.*

NOTE: For the unit conversion to successfully take place, the configuration of the respective instrument suffix must match the format highlighted in the configuration suite manual. For further details of module configuration, refer to DSE Publication: *057-299 DSEE050 Configuration Suite PC Software Manual.*





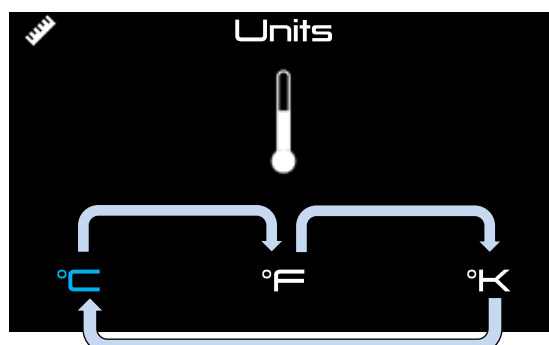

Allows for unit conversion without the need for a change in the modules configuration by simply cycling through the units as shown below. The blue highlighted suffix denoted the selected unit of measurement.

Use the button in line with the  icon to navigate through the available quantities and the button in line with the  icon to cycle through the suffix selection.



Commissioning

The available unit conversions within the menu are tabulated below.





Icon	Quantity	Suffix	Name
	Temperature	°C	Celsius
		°F	Fahrenheit
		°K	Kelvin
	Volume	L	Liters
		US gal	US Gallon
		m ³	Cubic Meter
	Flow Rate	l/m	Liter Per Minute
		gal/min	Gallon Per Minute
		m ³ /h	Cubic Meter Per Hour
	Speed	kph	Kilometer Per Hour
		mph	Mile Per Hour
		mps	Mile Per Second
	Torque	Nm	Newton-meter
		lb/ft	Pound-foot
	Fuel Consumption	Km/l	Kilometers Per Liter
		mpg(imp)	Miles Per Imperial Gallon
		mpg(US)	Miles Per US Gallon
	Pressure	Bar	Bar
		PSI	Pounds Per Square Inch
		kPa	Kilo Paskal

4.1.3 ICONS





NOTE: This section documents the Factory (Default) settings of the DSEE050. Due to the configurable nature of the device this is subject to change as required by the supplier. Contact supplier or consult the device configuration source for full details of the configured *Icons*.

4.1.3.1 LAMPS

NOTE: Diagnostic Lamps are enabled/disabled by the system installer. This section documents the Factory (Default) settings of the DSEE050 which has the *Display Engine Lamps on Module Enabled*. Due to the configurable nature of the device this is subject to change as required by the supplier. Contact supplier or consult the device configuration source for full details of the configured Icons.

Description	Lamps
Diagnostic Lamps	<p>When a Diagnostic Lamp is visible, press  to view the list of currently active <i>Diagnostic Trouble Codes</i> (DTCs). One is available for each of the J1939 DM1 Diagnostic Lamps (Red, Amber, Protect, Malfunction).</p> <div style="display: flex; justify-content: center; gap: 20px; align-items: center;"> <div style="text-align: center;">  Red </div> <div style="text-align: center;">  Amber </div> <div style="text-align: center;">  Protect </div> <div style="text-align: center;">  Malfunction </div> </div>

NOTE: Lamps have four possible display states. Off, On (Steady), Slow Flash (1 Hz), Fast Flash (2 Hz). The state is requested by the engine ECU. For descriptions of each state, Contact ECU supplier or manufacturer.

Lamp	Description
 Grey	All four lamps remain present in the display, even when inactive. In the inactive state, the lamp is shown as Grey.
 Red	This lamp is used to relay trouble code information that is of a severe enough condition that it warrants stopping the engine.
 Amber	This lamp is used to relay trouble code information that is reporting a problem with the vehicle system, but the engine need not be immediately stopped.
 Protect (Amber with P)	This lamp is used to relay trouble code information that is reporting a problem with the engine system that is most likely not electronic subsystem related. For instance, Engine Coolant Temperature is exceeding its prescribed temperature range.
 Malfunction (Red with M)	<div style="border: 1px solid black; padding: 5px; margin-bottom: 5px;"> <p>NOTE: This lamp is commonly referred to as MIL (Malfunction Indicator Lamp).</p> </div> <p>A lamp used to relay only emissions-related trouble code information. This lamp is only illuminated when there is an emission-related trouble code active. Non-emissions related trouble codes do not illuminate the lamp.</p>

4.1.3.2 ICONS

NOTE: This section documents the Factory (Default) settings of the DSEE050. Due to the configurable nature of the device this is subject to change as required by the supplier. Contact supplier or consult the device configuration source for full details of the configured *Icons*.

NOTE: The Factory Settings for the *Icons* rely on Factory Settings for the relevant SPNs within *CAN Receive*. Removing or changing the relevant SPNs in *CAN Receive* will prevent correct operation of the Factory Set *Icons*.

NOTE: The Factory Settings for the *Icons* use a grey colour of the icon to mean *Inactive*. Yellow, Red and White Icons are used to show *Active* status as detailed below.

Display	Description
	Diagnostic Lamps. See section entitled <i>Lamps</i> for details.
	Engine ECU Red Stop Lamp (SPN 623) is active.
	Engine ECU Amber Stop Lamp (SPN 624) is active.
	<i>Aftertreatment 1 Diesel Particulate Filter Soot Load Percent</i> is reporting <i>High, Most Severe</i> . (SPN 3719, FMI 0)
	<i>Aftertreatment 1 Diesel Particulate Filter Soot Load Percent</i> is reporting <i>High, Moderate</i> . (SPN 3719, FMI 16)
	Steady: Diesel Particulate Filter Regeneration is not needed. (SPN 3697, FMI 1)
	Flashing Slow (1 Hz): Diesel Particulate Filter Regeneration is reporting <i>Service Level</i> . (SPN 3697, FMI 4)
	Diesel Particulate Filter Regeneration is Inhibited. (SPN 3703, FMI 0)
	Steady: Diesel Exhaust Fluid is Low. (SPN 3517, FMI 1)
	Flashing Slow (1 Hz): Diesel Exhaust Fluid is very low. (SPN 3517, FMI 4)
	Steady: SCR Anomaly. Operator Warning System Active. (SPN 5246, FMI 1)
	Flashing Slow (1 Hz): SCR Anomaly. Low Level Inducement Enabled or Active. (SPN 5246, FMI 2 or FMI 3)

Continued Overleaf.

Display	Description
	<p>CAN data is not received. The following additional actions are taken:</p> <ul style="list-style-type: none"> • All CAN instrumentation changes to display # # # #. • TSC1 (Speed Control) messages are disabled (if enabled). • Outputs return to their default state as specified in the configuration. Factory Setting – Outputs return to 0 V. <p>This Could indicate a powered down ECU or a fault with the CAN connection.</p>
<p>1/5</p>	<p>When viewing instruments: Shows the total number of available instrumentation pages and the currently viewed page. i.e. 1/5 = Viewing page 1 of 5.</p> <p>When viewing DM1 and DM2 messages: Shows the total number of DTCs. Active DTCs (DM1) + Previously Active DTCs (DM2). i.e. 1/5 = Viewing DTC 1 of 5. (The number of DM1 + DM2 = 5).</p>

5 FAULT FINDING

 **NOTE:** For further details of DSEE050 Configuration, refer to DSE Publication 057-299 *DSEE050 Configuration Suite PC Software Manual*.

Issue	Check
Display and buttons are not illuminated.	If <i>Power Saving</i> is enabled within the device configuration, the backlight and button lights are extinguished after a (configurable) delay. Illumination resumes upon CAN data being received or upon the press of any button.
Display Backlight and/or buttons dim during engine start procedure.	This is to reduce power usage. The LCD backlight and button backlights are switched off when the DC supply falls. This occurs most commonly during engine cranking. However, this can also be a symptom of an electrical fault such as a depleted battery or failing battery charge system.
Button backlights do not illuminate; however, the display remains illuminated.	Should the device internal temperature be too high, the button lights are extinguished to lower the temperature and protect the internal systems. Ensure adequate ventilation to ensure the temperature of the device does not exceed specifications.
Inputs and outputs cease to function during engine start procedure.	This is to reduce power usage. Device inputs and outputs are disabled when the DC supply falls. This occurs most commonly during engine cranking. However, this can also be a symptom of an electrical fault such as a depleted battery or failing battery charge system.
CAN messages not received.	<ul style="list-style-type: none"> • Check the CAN connections are correct including cable type and termination resistors as specified in the section entitled <i>Connection Description</i> elsewhere in this document. • Factory Settings (defaults) of DSEE050 expects the ECU to send CAN data from Source Address 0. Where the ECU is not Source Address 0, the <i>CAN ID</i> of the messages to receive must be amended in the configuration of DSEE050. • Factory Settings (defaults) of DSEE050 expects the ECU to send CAN data with the priority as specified by SAE J1939 for <i>Default Priority</i>. Where the ECU sends messages of differing priority, the <i>CAN ID</i> of the messages to receive must be amended in the configuration of DSEE050.
++++, ----, XXXX, ##### shown on the display.	<p>These are displays to show an abnormal instrument value or an instrument in a fault condition. For further details see the section entitled <i>Engine and Analogue Input Instrumentation Sentinel Values</i> elsewhere in this document.</p> <p>If most instruments are displaying ##### along with the  icon, this indicates CAN communications is not functioning. See <i>CAN Messages not Received</i> elsewhere in this section.</p>
##### is shown for some instruments while others display correctly.	<ul style="list-style-type: none"> • Check the CAN connections are correct including cable type and termination resistors as specified in the section entitled <i>Connection Description</i> elsewhere in this document. • This instrument may not be supported by the engine ECU. Contact system supplier/installer for advice how to remove this instrument from the device.

Commissioning

Issue	Check
The engine shut down with a fault displaying. However, upon repowering the ECU, there are no DTCs present in the DM1 list.	If the ECU powers down after a fault shutdown, DM1s are moved to the DM2 list and cleared from the DM1 list. As such they appear as 'grey' colour to show they are DM1s.

6 MAINTENANCE, SPARES, REPAIR AND SERVICING

The controller is *Fit and Forget*. As such, there are no user serviceable parts within the controller. In the case of malfunction, you should contact your original equipment manufacturer (OEM).

Description	DSE Part	Manufacturer Part	Manufacturer
DSEE050 Connector A	007-850	DT16-18SA-K004	TE / Deutsch
Connector Pin Crimp (0.5 mm ² to 1.0 mm ²)	N/A	0462-201-16	TE
Connector Pin Crimp (2 mm ²)		0462-209-16	TE
DSEE050 Connector Harness Kit	016-176	N/A	DSE
DSEE050 Connector Configuration Harness.	016-177	N/A	DSE
Pin Blank Inserts (Seals unused connector pins)	N/A	114017	TE
Belden 9841 (CAN Cable)	016-030	9841	Belden
PCAN-USB PC Configuration Interface	016-179	IPEH-002021 or IPEH-002022	PEAK-System Technik GmbH
Rear Case Ring Nut	020-1058-01	N/A	DSE

6.1 DSEE050 CONNECTOR HARNESS (016-176)

DSE Part 016-176 consists of a cable with connector fitted at one end, with cable marking to identify the wires at the other end.

	Connector A
Assembly Ident	007-850
AMP Connector	DT16-18SA-K004
No of Connections	18
Wire size	0.5 mm ² (AWG 20)
Wire Colour	Black
Wire Idents	1 to 18
Connector Pin Crimp (0.5 mm ² to 1.0 mm ²)	0462-201-16
Connector Pin Crimp (2 mm ²)	0462-209-16

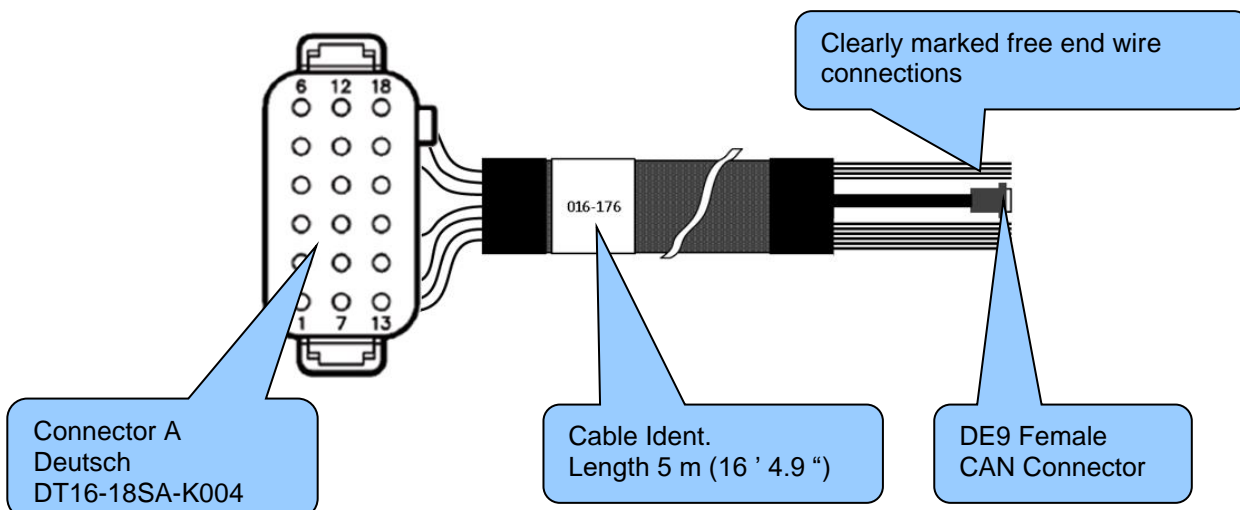

6.2 DSEE050 CONFIGURATION HARNESS (016-177)

NOTE: DSEE050 Configuration Harness 016-177 must be used in conjunction with Peak Systems USB CAN interface IPEH-002021 or IPEH-002022 from <https://www.peak-system.com>

DSE Part 016-177 consists of a minimal cable with connector fitted at one end with DC supply wires and DE9 CAN connector at the other end. This is designed to connect to the DE9 connector of the USB CAN interface.

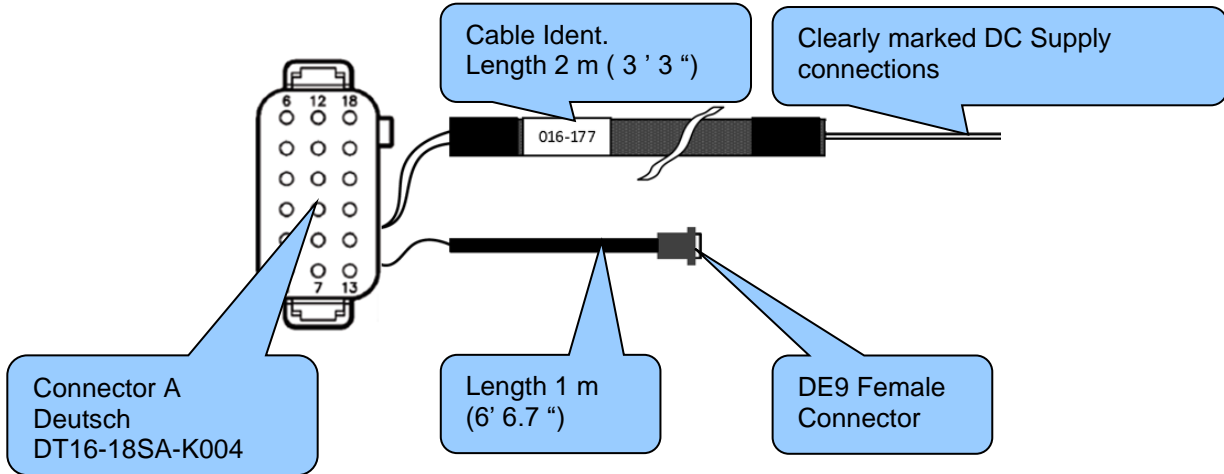

Description	Connector A	Termination
DC Positive	7	Single wire
DC Negative	1	Single wire
CAN SCR	2	DE9 Pin 5
CAN L	3	DE9 Pin 2
CAN H	4	DE9 Pin 7

6.3 PCAN-USB CONNECTION DETAILS

NOTE: Where a DSE Configuration or Connection Harness is not used, connection details for PCAN-USB are shown below. PCAN-USB supplier details are given in the section entitled *Maintenance Spares, Repair and Servicing* elsewhere in this document.

NOTE: DSE Stock and supply PCAN-USB IPEH-002021. DSE Part number 016-179. Contact sales@deepseaelectronics.com.

Connect PCAN-USB to DSEE050 using connections for CAN H, CAN L and GND. For suitable connection looms from DSE, see DSE Publication 057-300 *DSEE050 Operator Manual*.

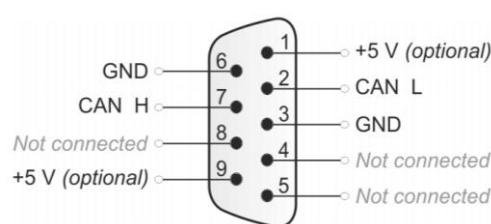

Shown looking at the PCAN-USB interface from the 'outside'

7 WARRANTY

DSE Provides limited warranty to the equipment purchaser at the point of sale. For full details of any applicable warranty, refer to the original equipment supplier (OEM)

8 DISPOSAL

8.1 WEEE (WASTE ELECTRICAL AND ELECTRONIC EQUIPMENT)

If you use electrical and electronic equipment you must store, collect, treat, recycle and dispose of WEEE separately from your other waste



This Page is Intentionally Blank

This Page is Intentionally Blank